

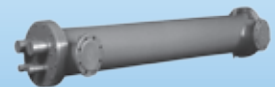

INDUSTRIAL FLUID CHILLERS

FC SERIES (20 - 400 TONS)



Nortec Industrial Fluid Chillers

Application Flexibility

- ◆ High Performance
- ◆ Better Efficiency
- ◆ State-of-the-art Technology

Flexibility of design and product adaptability sets Nortec apart from the rest in the industry. Each unit is individually designed and manufactured to meet your exact specifications. Chillers are available from 20-400 tons capacities with user selectable cooling - Air cooled or Water cooled, and with single, duplex or multiple refrigeration circuits. A long list of available options helps you choose the components needed for your application. Quality engineering and manufacturing is the key element of our flexibility.

Why You Need a Chiller?

Equipment Protection

The most compelling reason for a chiller is the continuous protection it provides to your valuable process equipment. It represents a small fraction of the investment, yet it extends the life of your equipment by many years.

Increased Production

By maintaining a constant cooling temperature in the production process, the speed and accuracy of parts produced is greatly enhanced. You may ask yourself: "Does my equipment shut down during summer months?" A water tower may provide adequate cooling during fall and winter months, but fail during the summer months. A water chiller will immediately eliminate this problem.

Save Water and Related Costs

With today's environmental issues and limitations, even the use of 20 gallons of city water per minute (2.4 million gallons of water per year) - will be a significant addition to your manufacturing costs. With the use of a Nortec chiller, you will not only eliminate this cost permanently but you will not have any environmental issues to worry about. By doing a cost analysis, you will be surprised to realize how quickly a chiller ends up paying for itself and then saving you money for years to come.

Typical Applications

- ◆ Lasers
- ◆ Molds and Dies
- ◆ High temp. mixers
- ◆ Printers
- ◆ Welders
- ◆ Injection & Blow molding
- ◆ Plasma cutting
- ◆ Food processing

Principle Of Operation

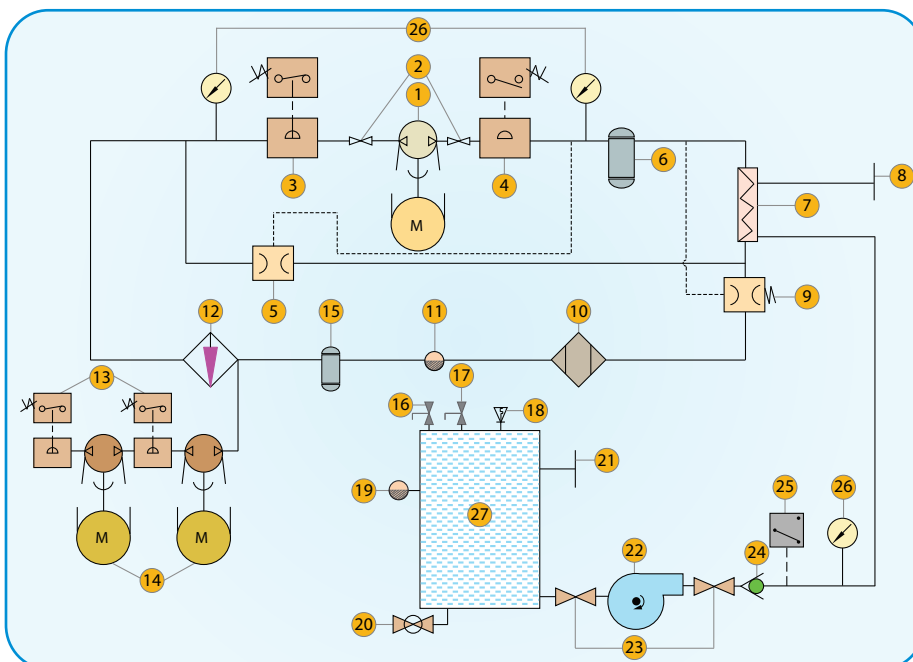

1 Compressor	15 Receiver
2 Isolation Valve	16 Bleed Valve
3 High Pressure	17 Fill Port
4 Low Pressure	18 Safety Valve
5 Hot Gas By-pass	19 Sight Glass
6 Suction Accumulator	20 Drain Valve
7 Evaporator	21 Return
8 Cold Fluid Outlet	22 Pump
9 Thermo. Exp. Valve	23 Isolation Valve
10 Refrig. Filter Drier	24 Check Valve
11 Sight Glass	25 Flow Switch
12 Condenser	26 Gauge
13 Fan Cycle Switch	27 Expansion Tank
14 Condenser Fan Motor	

Nortec Industrial Fluid Chillers

Standard Features

- 1 High efficiency scroll hermetic compressor (20-50 tons)
- 2 Semi hermetic piston compressor with unloading capacity 33%, 66%, 100% (30-60 tons)
- 3 Semi hermetic rotary screw compressor with unloading capacity 25%, 50%, 75%, 100% (60-500 tons)
- 4 Compressor discharge service valve
- 5 Compressor suction service valve
- 6 Compressor oil separator (rotary screw)
- 7 Compressor internal discharge check valve
- 8 Liquid line filter drier
- 9 Liquid line sight glass
- 10 Liquid line solenoid valve
- 11 Thermostatic expansion valve
- 12 Hot-gas by-pass valve
- 13 Shell & tube or stainless steel brazed plate evaporator
- 14 Suction/discharge refrigeration pressure gauge
- 15 High/low refrigeration safety switch
- 16 Freeze control thermostat
- 17 Process water pump
- 18 Expansion tank
- 19 Pump isolation valves
- 20 Motor starter and overload protection
- 21 Power ON light
- 22 Power ON switch
- 23 Failure alarm
- 24 No flow shut-down
- 25 NEMA 1 electrical
- 26 Pump pressure gauge
- 27 Refrigerant: R-22, R-134A, R407C & R404A
- 28 One year parts and labor warranty

Optional Features

- 1 Outdoor application NEMA 4, NEMA 3R electrical
- 2 Hazardous environment NEMA 7 electrical
- 3 Duplex pumping station
- 4 Duplex or multiplex refrigeration circuits
- 5 Optional voltage: 575-3-60 or 380-3-50
- 6 Low ambient package
- 7 Main power disconnect switch
- 8 Line voltage and phase monitor
- 9 Air cooled condenser with fan cycle control
- 10 Extended compressor warranty
- 11 Programmable Logic Controller (PLC)

Typical Duplex Chiller Configuration

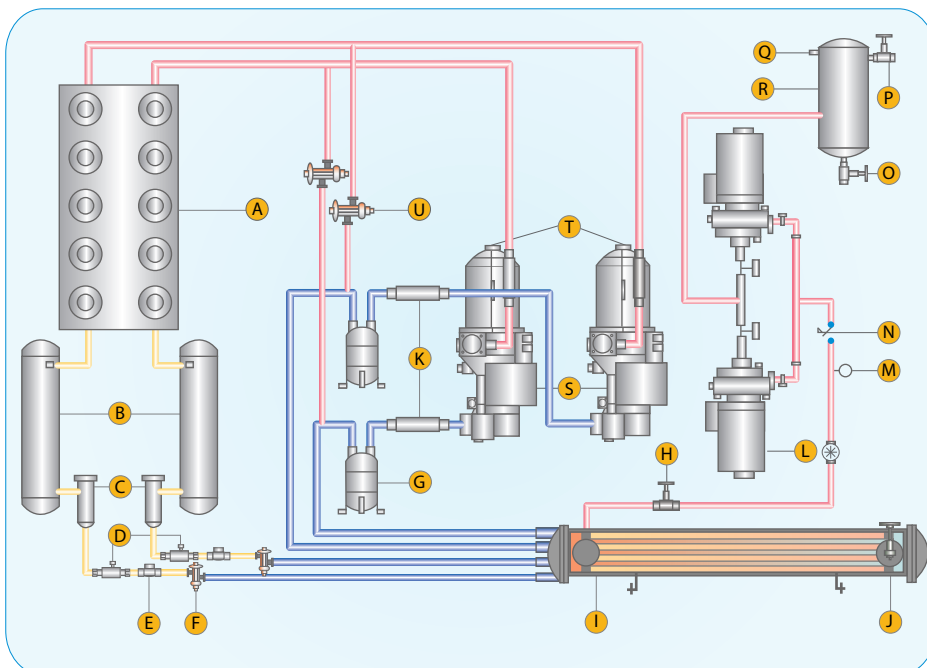

A	Condenser	L	Pump
B	Liquid Receiver	M	Gauge
C	Filter Dryer	N	Flow Switch
D	Solenoid	O	Drain Valve
E	Sight Glass	P	Inlet
F	Expansion Valve	Q	Bleed Valve
G	Suction Accumulator	R	Expansion Tank
H	Balancing Valve	S	Service Isolation Valve
I	Chiller Evaporator	T	Rotary Screw Compressor
J	Outlet	U	Hot Gas By-pass Valve
K	Vibration Eliminator		

Nortec Industrial Fluid Chillers

Specifications

Model	Capacity		No. of comp.	Power Input KW	FLOW GPM	FLA @ 460 3 60	PUMP				IN/OUT Connections	Dimensions L x W x H (Inches)	Weight (Lbs)
	BTUH	Tons					HP	GPM	PSIG	FLA			
20-FCW	224,000	19	2	17	45	25	3.0	70	32	3.4	2" NPT	110x40x60	3700
25-FCW	270,600	23	2	20	54	29	3.0	70	30	3.6	2" NPT	110x40x60	3900
30-FCW	337,000	28	2	24	67	35	5.0	110	35	5.8	3" FLG	110x40x60	4100
40-FCW	411,000	34	1	42	82	60	5.0	110	33	6.1	3" FLG	90x45x50	4600
50-FCW	486,000	40	1	51	97	76	5.0	110	30	6.5	3" FLG	90x45x50	5010
60-FCW	532,000	45	1	47	107	67	7.5	150	39	9.1	3" FLG	110x45x50	5250
70-FCW	615,000	51	1	55	123	78	7.5	150	33	9.5	4" FLG	120x50x60	5500
80-FCW	727,000	61	1	63	146	89	10.0	250	41	11.8	4" FLG	120x50x60	6700
90-FCW	826,000	70	1	71	165	97	10.0	250	39	12.0	4" FLG	130x60x75	7100
100-FCW	1,033,000	86	1	86	207	121	10.0	250	35	12.5	6" FLG	130x60x75	7600
125-FCW	1,184,000	95	1	98	237	140	15.0	300	40	17.5	6" FLG	135x89x60	8600
150-FCW	1,454,000	121	2	126	291	178	15.0	300	30	18.7	6" FLG	135x89x60	10800
200-FCW	2,066,000	172	2	172	413	242	20.0	500	35	23.8	8" FLG	135x89x60	13600
250-FCW	2,368,000	197	2	196	474	278	20.0	500	30	24.5	8" FLG	135x89x60	14700
300-FCW	2,908,000	242	4	252	582	356	25.0	600	31	29.0	8" FLG	CF	CF
350-FCW	3,304,000	275	4	284	661	388	30.0	700	30	35.0	10" FLG	CF	CF
400-FCW	4,132,000	344	4	344	826	484	40.0	850	30	51.0	12" FLG	CF	CF
500-FCW	4,736,000	395	4	392	947	556	50.0	1000	30	64.0	12" FLG	CF	CF

Capacity based on 90°F ambient temperature and 55°F EWT (inlet) and 45°F LWT (outlet). Pumping station is optional.

Specifications subject to change without notice.

How To Size a Chiller

Capacity Correction Factors

Chilled water temp. °F	20	30	40	45	50	55	60
Factor F1	0.61	0.76	0.95	1.0	1.12	1.19	1.22

Ambient Temperature °F	70	80	90	100	105	110	120
Factor F2	1.1	1.05	1.03	1.0	0.81	0.70	0.60

Altitude Feet	Sea Level	2000	4000	6000	8000
Factor F3	1.0	0.997	0.994	0.989	0.980

Condensing Water temp. °F	75	80	85	90	95	100	105
Factor F4	1.1	1.05	1.0	0.95	0.92	0.80	0.70

Glycol Concentration %	10	20	30	40	50	55	60
Factor F5	0.99	0.98	0.97	0.96	0.94	0.91	0.86

$$\text{Capacity (Tons)} = \frac{\text{GPM} \times \text{Delta T}}{24 \times F1 \times F2 \times F3 \times F4 \times F5}$$

Example: What is the chiller size (tons) for the following conditions?

Flow rate: 85 GPM
 Chill water temperature: 40° F
 Ambient Temperature: 90° F
 Altitude: 4000 Feet
 Condenser Air Cooled
 Glycol Concentration: 30%
 Fluid Inlet temperature: 50° F

$$\text{Capacity (tons)} = \frac{85 \times 10}{24 \times 0.95 \times 1.03 \times 0.994 \times 0.97}$$

Capacity= 37.53 tons. You need chiller 40-FCW

Chiller Operating Limits

- ◆ Max. ambient temp. 120° F
- ◆ Max. operating ambient temp. 110° F
- ◆ Min. operating ambient temp. 35-65° F
- ◆ Leaving chilled water temp. 38° F
- ◆ Leaving chilled water temperature with glycol solution: 20-65° F
- ◆ Standard temperature difference (Inlet-outlet) 10° F
- ◆ Operating temperature difference: 5-20° F
- ◆ Max. operating inlet fluid temp. 80° F
- ◆ Max. non operating fluid temp. 110° F
- ◆ Min. water volume 2-3 times of flow rate
- ◆ Min. glycol concentration 20-25% for bacterial and corrosion protection.

Nortec Industrial Fluid Chillers

Nortec Advantages

The performance of any chiller depends on the quality of its key components. Nortec uses the best available compressors, condensers, evaporators, pumps and controllers. With accurately designed and sized components, the chillers are manufactured to provide years of trouble free operation.

Rotary Screw Compressor



Semi Hermetic Reciprocating Compressor



High Efficiency Scroll Compressor



Depending on the capacity and application, one of these three types of high quality energy saving compressors are used on Nortec machines.

- ◆ High Efficiency Scroll Compressor
- ◆ Semi Hermetic High Performance Piston Compressor
- ◆ Semi Hermetic Energy Saver Screw Compressor
- ◆ Open Drive Rotary Screw Compressor.

Air Cooled Condenser



Air cooled condensers are constructed from high thermal efficiency copper tubes, coils and aluminum fins and are rated for 100° F ambient temperature.

Water Cooled Condenser



Water cooled condensers are designed according to ASME standards with carbon steel shell and copper tubes to provide adequate cooling capacity that exceeds the refrigeration demand. All Nortec water cooled units are equipped with head pressure control and energy saver water regulating valve.

Evaporator

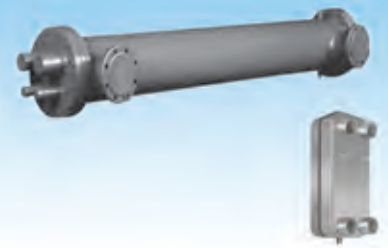

Fluid chill evaporators are either shell-and-tube type or brazed stainless steel plate type and are designed for high heat transfer efficiency. Each refrigeration zone has its own independent evaporator, so failure of one refrigeration compressor will have no effect on the other circuits.

Pump



Nortec closed coupled and base mounted centrifugal pumps provide economical performance for a wide range of applications of varying flow rate and head pressure. (Flow rates up to 500 GPM and head pressure up to 140 feet). These high quality pumps meets low net positive suction head pressure requirements (NPSHR) without sacrificing efficiency. The large seal chamber provides a wide fluid passage for maximum cooling of the seal face and allows debris and gases to be flushed away.

Nortec Industrial Fluid Chillers

Controller



Nortec uses the state of the art controllers for optimizing the performance of these chillers. PLCs (Programmable Logic Controller) are designed with ease-of-use in mind. Their modular and versatile features make it suitable for various applications including local and remote display. Close monitoring of the supply water temperature and total control of the chiller operation allows the user to receive the highest performance from the chiller. Two methods of unloading help achieve optimal stability during variation in heat loads while maintaining constant outlet temperature and minimizing power consumption. Units that use multiple compressors monitor the outlet temperature to determine the independent unloading of each of the compressors. This energy saving feature ensures optimal energy usage and decreases the compressor wear and tear. Optional PC connections are also available.

NORTEC CORPORATION

Compressed Air, Gas & Fluid Technologies

1713 Henry G. Lane, Maryville TN 37801

Tel: 865-980-6100 Fax: 865-980-6190

www.nbdry.com



Water Saver and Pumping Stations



High Capacity Dryers



Fluid Chillers



Refrigerated Dryers



Desiccant Dryers
Heatless & Heated